

Daytime Fan-Aspirated Radiation Shield Kit

7747

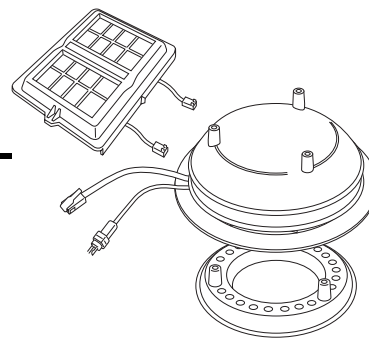

Vantage Pro2™ Accessories

The Daytime Fan-Aspirated Shield Kit can be installed on any Vantage Pro2 standard ISS model to provide even more accurate temperature and humidity readings. The kit contains a solar-powered fan that draws outside air over the temperature and humidity sensors to reduce the effects of daytime radiation on temperature and humidity readings. The solar-powered fan runs during the day. Since there is no backup battery, the fan will cease running when night falls and the effects of the radiation are minimal.

The kit includes fan, solar panel, additional radiation shield places, and hardware.

Please refer to the WeatherLink for Vantage Pro2 Spec Sheet for optional data logging and charting capabilities available for this product.

General

Operating Temperature	-40° to +150° F (-40° to +65° C)
Storage Temperature	-50° to +158° F (-45° to +70° C)
Radiation Induced Error	+1.0° F (0.5° C) at solar noon (insolation = 1040 W/m ² , avg. wind speed ≤ 2 mph (1 m/s)) (reference: RM Young Model 43408 Fan-Aspirated Radiation Shield)
Housing Material	UV-resistant plastic

Package Dimensions

Product #	Package Dimensions (Length x Width x Height)	Package Weight	UPC Codes
7747	12.00" x 10.00" x 6.00" (305 mm x 254 mm x 153 mm)	2.7 lbs. (1.2 kg)	011698 00786 8